

BRECOflex CO., L.L.C.

High Precision Drive Components

The World Leader In Polyurethane Timing Belts

SM5

Universal Belt Tension Meter



SM5 Tension Meter

Overview

The **SM5 Tension Meter** is designed to measure the static tension of all belt types and materials and offers the following benefits:

- Simple one-button operation
- Accurate measurement results for optimal belt performance and life
- Save production and downtime with quick readings
- Satisfy quality system requirements with traceable certification
- Integrates with our online calculation program
 - www.brecoflex.com/support-resources/calculation-program
- Download the SM5 Pretension Calculator Phone App free for iOS and Android

The purpose of pre-tensioning a belt is to maintain tension at all times during operation. The amount of pre-tension depends on the belt drive type and peak loading. Minimizing pretension reduces bearing and shaft loading and preserves belt tensile safety factors. Minimum pretension is achieved when the belt does not sag or flap under peak running load. Maximum pretension is limited by the belt strength and machine design (shafts, bearings and frame).

Characteristics:

- Measuring range: from 7 to 450 Hz
- Measurement tolerance: ± 5 Hz
- Weight: 148g
- Dimensions (LxWxH): 117 x 78 x 24mm
- Battery: 9Volts
- Conforms to EC standard



SM5 Tension Meter

Operation Instructions



1. **PRESS** button (1) one second to activate meter
2. **AIM** light beam at belt back with a sensor distance of 0.4 to 1.2 inches
3. **TAP** belt to generate a vibration and SM5 will display a frequency
4. **WAIT** for “Ready” display and repeat measurement to confirm reading
5. **PRESS** button (1) one second to turn off meter or meter will auto power off after one minute

Tips and Notes:

- Turn off the machine as well as nearby machinery that could cause vibration interference while measuring.
- For best results take readings on the belt back rather than tooth side or edge.
- Take a few readings to confirm consistency.
- For long belt spans better reading and resolution can be achieved by temporarily shortening the vibrating free span **L** to around 1 meter.
- Frequency recommendations from calculations or our belt sizing program are initial theoretical settings and should be confirmed as optimal by observation for no signs of sag or flapping during operation. Once optimal tension is found then a new reading should be taken and recorded for future use.
- New belts conform to the geometry of a system and lose up to 10% pre-tension within the first few hours of run-in. Machine manufacturers often recommend different frequency settings for new and used belts for this reason.
- We offer a certification service for traceability. Calibration interval depends on use/environment and is up to the customer. Please contact customer service for pricing, turn around time and a return authorization number.

Types of Belt Drives:

Select the type of belt drive below to determine required pretension (**Fv**) as a function of peripheral force. These values are a starting point and tension should be increased as necessary to eliminate sag or flapping during peak peripheral belt loading.

Two Pulley Drive	
# of belt teeth	Pre-tension Fv
< 60 teeth	Fv = 1/3 peripheral force
60 to 150 teeth	Fv = 1/2 peripheral force
> 150 teeth	Fv = 2/3 peripheral force

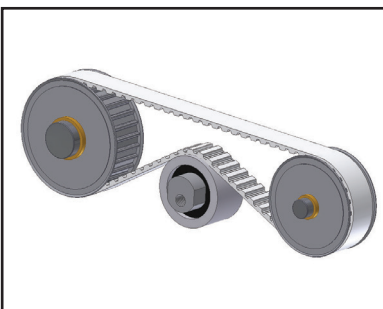

Linear Drive	
Belt Span	Pre-tension Fv
Any	Fv = peripheral force

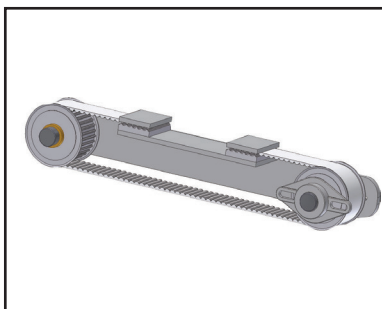

Multiple Pulley Drive	
Belt Span	Pre-tension Fv
Taut Length < slack length	Fv = peripheral force
Taut Length > slack length	Fv > peripheral force

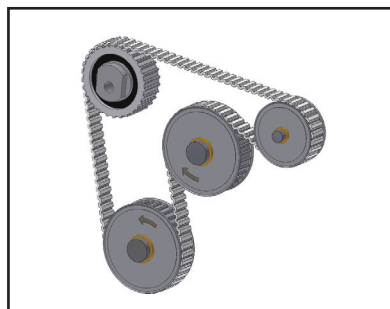

SM5 Tension Meter

Check and Set Pre-tension

Use the SM5 to check belt pre-tension

Calculate the pre-tension **Fv** using the frequency **f** read from the meter

$$F_v = f^2 \cdot L^2 \cdot 4 \cdot m \cdot b$$

F_v [N]	current pre-tension in Newtons (1lbf = 4.45N)
f [Hz]	frequency read from the meter
L [m]	free vibrating span length in meters
m [Kg/m/cm]	belt mass in kilograms per meter of length per centimeter belt width
b [cm]	belt width in cm (1" = 2.54cm) (1cm = 10mm)

Use the SM5 to set belt pre-tension

Calculate the frequency **f** required to achieve a target frequency **Fv**. Alternately use our online calculation program recommendation.

$$f = \sqrt{\frac{F_v}{L^2 \cdot 4 \cdot m \cdot b}}$$

F_v [N]	target pre-tension in Newtons (1lbf = 4.45N)
f [Hz]	frequency reading
L [m]	free vibrating span length in meters
m [Kg/m/cm]	belt mass in kilograms per meter of length per centimeter belt width
b [cm]	belt width in cm (1" = 2.54cm) (1cm = 10mm)

Belt Mass - Steel Cord [kilograms per meter of belt length per centimeter of belt width]					
Belt Pitch	Single Sided	Double Sided	Belt Pitch	Single Sided	Double Sided
AT3	0.0216	-	T5	0.0233	-
AT5	0.0327	0.041	T5-DL	0.0283	-
AT5-DL	0.0410	-	T10	0.0454	-
ATL5	0.0374	-	T10-DL	0.0586	0.028
ATN12.7	0.0444	-	T20	0.0736	-
ATN10	0.0480	-	T20-DL	0.0986	0.058
AT10	0.0581	-	MXL	0.0120	-
AT10-DL	0.0755	0.076	T1/5"	0.0240	-
AT10 MOV	0.0701	-	T3/8"	0.0349	0.100
ATL10	0.0680	-	T1/2"	0.0425	-
BAT10	0.0581	0.077	T1/2"-DL	0.0519	-
BATK10	0.0600	-	T7/8"	0.1042	-
ATP10	0.0600	-	HTD3M-HP	0.0310	0.052
ATP10-DL	0.0636	0.064	HTD5M-HP	0.0410	-
SFAT10	0.0581	-	HTD5M-HF	0.0340	-
ATS15	0.1000	0.118	HTD8M-HP	0.0630	-
ATS15-DL	0.1178	-	HTD8M-HF	0.0540	-
BAT15	0.0856	0.088	HTD14M-HP	0.1130	-
BATK15	0.0856	-	F1	0.0150	-
ATP15	0.0800	0.125	F2	0.0322	-
ATP15-DL	0.0876	-	F2.2	0.0366	-
SFAT15	0.0875	-	F2.5	0.0526	-
AT15 MOV	0.0946	-	F3	0.0686	-
ATN20	0.0806	-	F6	0.0773	-
AT20	0.0960	-	Type13	0.0769	-
AT20-DL	0.1140	-	Type17	0.1290	-
ATL20	0.1110	-	Type20	0.1250	-
SFAT20	0.0960	-	Type30	0.1930	-
T2	0.0120	-	Type32	0.2340	-
T2.5	0.0150	-			

Note: These values are built in to the BRECOflex SM5 Pretension Calculator App. Download the App for free for iOS on The App Store or Android on Google Play.

For videos on how to use the SM5 Tension Meter, calculate pre-tension, use the SM5 Pretension Calculator App and more, visit our YouTube channel at www.youtube.com/brecoflexcollc.

SM5 Tension Meter

SM5 Pretension Calculator App

BRECOflex CO., L.L.C. offers the free “SM5 Pretension Calculator” which is a companion App to the SM5 Tension Meter. The two work together to make setting and calculating belt pretension simple and right at your fingertips. Scan the QR codes below with your smart phone to download it free directly from Google Play, coming soon to iOS.

Advantages:

- Our app doesn't require math and yields an instant, accurate result making it simple to use
- The user can translate it into English, Spanish, French or German with the touch of a button
- It eliminates the need to reference external charts to find the proper belt mass because they are built into the functionality
- BRECOflex keeps the App updated with the most recent belt pitch and belt mass data to ensure the most accurate pre-tension calculations for your belt

