



The Perma-Tork® permanent magnet hysteresis clutches and brakes provide constant torque independent of slip speed and are popular in light tensioning and torque limiting applications.

Hysteresis units produce highly accurate, dependable and repeatable torque without an external power source.

Hysteresis units offer excellent overload and jam protection for drive train components, as well as zero slip until a pre-set torque is reached. In addition, the units do not require maintenance and provide extremely long life.



GENERAL SPECIFICATIONS

Torque Range across Models:
0.001 to 6.2 Nm

Torque Adjustment:
The constant torque is set mechanically with a scaled ring on the housing.

Max. Rotation Speed:
1800 to 5000 1/min, varying by model

Clutch models:
– Supplied with hollow shaft.
– Available in metric or imperial dimensions.
– Can be used as brake.

Brake models:
Supplied with full shaft.

Stub Shaft Adapter:
Available for clutch models.

KEY FEATURES

- Constant torque independent of speed
- Torque infinitely adjustable in range
- No external control or power source required
- Long life due to non-contact internal operation
- Stub shaft adapters available for in-line applications
- Hysteresis models can be installed in any orientation

LIST OF MODELS

Five clutch and three brake types are available to fit many applications and brake requirements. Clutch models can be used as brakes when accordingly mounted.



HC01-1 Clutch



HC2 Clutch



HC4 Clutch



HC5 Clutch



HC6 Clutch



HB-1/2 Brake



PB6 Brake



HB6 Brake

Metric Models

Model	Torque Range [Nm]	Heat dissipation [W]	Inertia [kgmm ²]	Max. Rotation Speed [1/min]	Weight [kg]
HC2-M6	0.0071 - 0.141	10	0.211	1800	0.28
HC4-M14	0.056 - 1.13	22	3.5	1800	1.13
HC5-M17	0.226 - 2.825	72	19.9	1800	3.63
HC6-M19	0.226 - 6.215	150	58.6	1800	5.44

Imperial Models

Model	Torque Range [Nm]	Heat dissipation [W]	Inertia [kgmm ²]	Max. Rotation Speed [1/min]	Weight [kg]
HC01-1	0.001 - 0.0077	3	0.012	3600	0.06
HB-1/2	0.0018 - 0.056	10	0.820	5000	0.31
HC2-14	0.0071 - 0.141	10	0.211	1800	0.28
PB6	0.056 - 0.678	15	0.703	1000	0.425
HC4-58	0.056 - 1.13	22	3.5	1800	1.13
HC4-12					
HC5-58	0.226 - 2.825	72	19.9	1800	3.63
HC5-12					
HC6-58	0.226 - 6.215	150	58.6	1800	5.44
HC6-34					
HB6-1					

MODEL NUMBER

H

C

2

—

M

6

H Hysteresis technology

P Magnetic Powder technology

C Clutch (hollow shaft)

B Brake (full shaft)

Type (Size)

Unit type
M Metric [mm]
Blank Imperial [inch]

Bore/Shaft diameter code (see dimensions for actual size)

CLUTCH DIMENSIONS

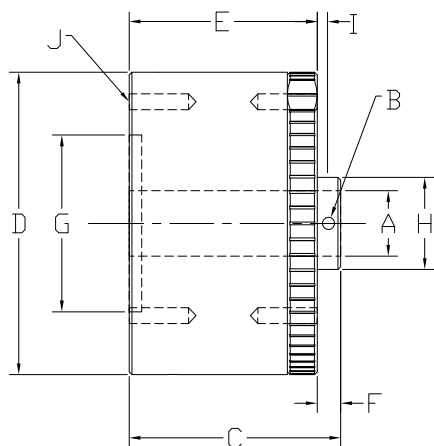

Drawing 1

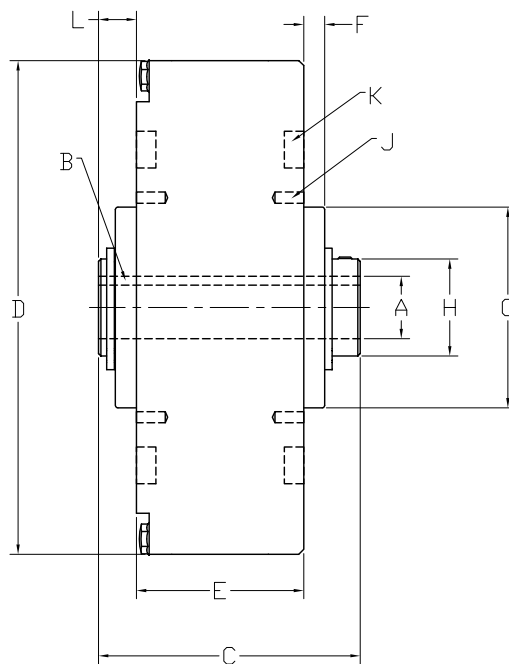

Drawing 2

Metric Clutch Models (Dimensions in mm)

Model	Drawing	A ¹	B ²	C	D	E	F	G ³	H	I	J ⁴	K ⁵	L
HC2-M6	1	6 H8	2.5 Roll Pin	40.9	47.0	34.5	6.4	22.225 X 2.0	9.53	3.785	M3 x 0.5 x 7.9, 31.8	-	-
HC4-M14	1	14 H8	5 Sq. Key	58.4	82.0	51.3	7.1	47.00 X 2.5	24.90	-	M5 x 0.8 x 9.5, 60.33	-	-
HC5-M17	1	17 H8	5 Sq. Key	73.4	118.1	62.7	10.7	62.00 X 3.0	34.90	-	M5 x 0.8 x 12,7, 76.2	-	-
HC6-M19	2	19 H8	6 Sq. Key	80.8	152.4	51.6	6.4	62.00	30.00	-	M6 x 1 x 7.9, 73.03	10.31 x 7.9, 101.6	11.8

1 Bore, Tolerance: H8

2 Models with square keyway have set screws in the hub extension

3 Dimension G is the same on both sides (Diameter x Deepness)

4 3x threaded hole, arranged in 120° steps on both sides (Thread Type x Pitch x Deepness, bolt circle diameter)

5 2x Centering hole, arranged in 180° on both sides (Diameter x Deepness, Bolt circle diameter)

Imperial Clutch Models (Dimensions in inch, UNC threads)

Model	Drawing	A ¹	B ²	C	D	E	F	G ³	H	I	J ⁵	K ⁶	L
HC01-1	1	-	Flat 0.169	1.378	1.024	0.83	0.55	0.392 x 0.37	0.197 ⁴	-	M3 x 4.5, 0.61	-	-
HC2-14	1	0.250	3/32 Roll Pin	1.61	1.88	1.36	0.25	0.8750 X 0.08	0.375	0.205	6-32 x 5/16, 1.25	-	-
HC4-58	1	0.625	3/16 Sq. Key	2.3	3.23	2.02	0.28	1.850 x 0.1	0.98	-	10-32 x 3/8, 2.375	-	-
HC4-12	1	0.500	1/8 Sq. Key										
HC5-58	1	0.625	3/16 Sq. Key	2.89	4.65	2.47	0.42	2.441 x 0.1	1.38	-	10-32 x 0.5, 3	-	-
HC5-12	1	0.500	1/8 Sq. Key										
HC6-58	2	0.625	3/16 Sq. Key	3.18	6	2.03	0.25	2.441	1.18	-	1/4-20 x 5/16, 2.875	0.406 x 0.31, 4	0.5
HC6-34	2	0.750	3/16 Sq. Key										

1 Bore, Tolerance: +0.001/-0.000

2 Models with square keyway have set screws in the hub extension

3 Dimension G is the same on both sides (Diameter x Deepness)

4 Full Shaft, Tolerance: +0.000/-0.001

5 3x threaded hole, arranged in 120° steps on both sides (Thread Type x Deepness, Bolt circle diameter)

6 2x Centering hole, arranged in 180° on both sides (Diameter x Deepness, Bolt circle diameter)

BRAKE DIMENSIONS

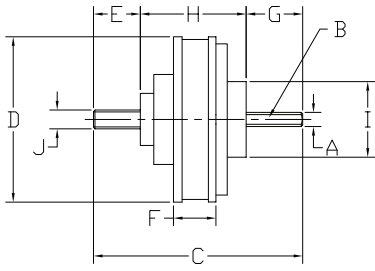

Drawing 3

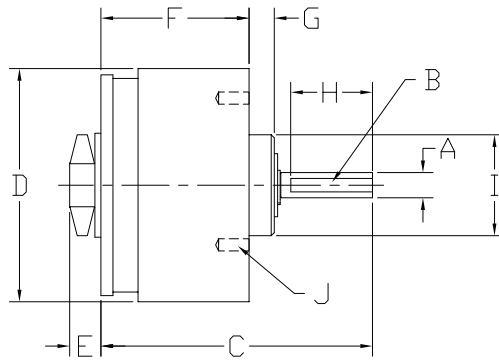

Drawing 4

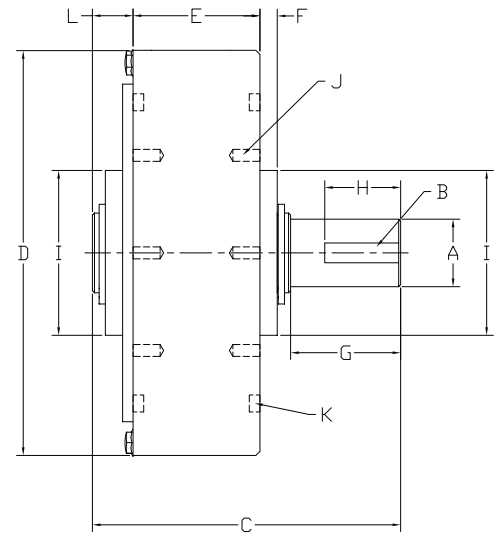

Drawing 5

Imperial Brake Models (Dimensions in inch)

Model	Drawing	A ¹	B	C	D	E	F	G	H	I	J	K ⁴	L
HB-1/2	3	0.187	Flat on shaft	2.8	2.19	0.62	0.64	0.8	1.4	1.0	1/4-20 Mounting stud	-	-
PB6	4	0.250	Flat on shaft	2.68	2.31	0.32	1.52	0.25	0.81	0.997	10-24 x 3/8, 1.75 ²	-	-
HB6-1	5	1.000	1/4 Sq. Key	4.57	6.00	2.03	0.25	1.63	1.12	2.441	1/4-20 x 5/16, 2.875 ³	0.406 x 0.31, 4	0.5

1 Full Shaft, Tolerance: +0.000/-0.001

2 3x threaded hole, arranged in 120° steps on shaft side (Thread Type x Deepness, Bolt circle diameter)

3 3x threaded hole, arranged in 120° steps on both sides (Thread Type x Deepness, Bolt circle diameter)

4 2x Centering hole, arranged in 180° on both sides (Diameter x Deepness, Bolt circle diameter)

MOUNTING EXAMPLES

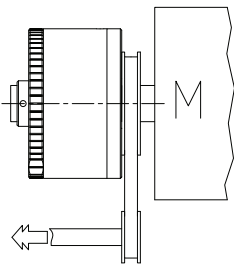

Parallel shaft or jack shaft
Motor Shaft mount and indirect coupling with attached pulley.

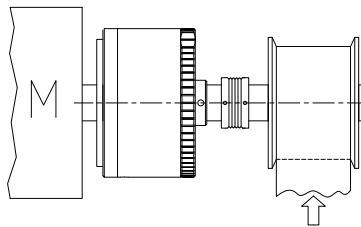

In-Line application
Typical torque limiting and jam load protection for labels, printing and capping.
Note:
Use a flexible coupling and support Perma-Tork carefully at both ends.

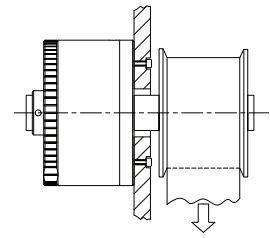

Brake application
Typical setup for tensioning wire, fiber, film on pay off.
Note:
The change in radius results in a change of tension

MAXCESS